



Published in final edited form as:

*J Theor Biol.* 2008 April 21; 251(4): 698–707.

## Evolutionary stability on graphs

Hisashi Ohtsuki<sup>1</sup> and Martin A. Nowak<sup>1,2</sup>

<sup>1</sup>Program for Evolutionary Dynamics, Harvard University, Cambridge MA 02138, USA

<sup>2</sup>Department of Organismic and Evolutionary Biology, Department of Mathematics, Harvard University, Cambridge, MA 02138, USA

### Abstract

Evolutionary stability is a fundamental concept in evolutionary game theory. A strategy is called an evolutionarily stable strategy (ESS), if its monomorphic population rejects the invasion of any other mutant strategy. Recent studies have revealed that population structure can considerably affect evolutionary dynamics. Here we derive the conditions of evolutionary stability for games on graphs. We obtain analytical conditions for regular graphs of degree  $k > 2$ . Those theoretical predictions are compared with computer simulations for random regular graphs and for lattices. We study three different update rules: birth-death (BD), death-birth (DB), and imitation (IM) updating. Evolutionary stability on sparse graphs does not imply evolutionary stability in a well-mixed population, nor vice versa. We provide a geometrical interpretation of the ESS condition on graphs.

### Keywords

evolutionary game theory; evolutionary graph theory; ESS; structured population; spatial games

## 1 Introduction

Evolutionary game theory is the study of frequency dependent selection (Maynard Smith 1982, Hofbauer & Sigmund 1998, Nowak & Sigmund 2004, Nowak 2006). The fitness of an individual is not constant, but depends on interactions with other individuals. These interactions can be described by a game. The payoff from the game affects fitness, which is reproductive success. Reproduction can be genetic or cultural.

An important concept in evolutionary game dynamics is that of an evolutionarily stable strategy (ESS) (Maynard Smith & Price 1973, Maynard Smith 1974, 1982). If all players of a population adopt that strategy, then no mutant strategy can invade. The traditional ESS condition is defined for infinitely large, well-mixed populations. In a well-mixed population, every individual interacts with every other individual equally likely. Real populations are, of course, neither infinitely large nor well-mixed. Various attempts have been made to extend the ESS concept to populations of finite size (Maynard Smith 1988, Schaffer 1988, Ficici & Pollack 2000, Neill 2004, Nowak et al. 2004, Wild & Taylor 2004, Traulsen et al. 2006).

In spatial evolutionary game theory (Nowak & May 1992), the players of a population are arranged on a spatial grid and interact with their nearest neighbors. Spatial games can lead to very different evolutionary dynamics than games in well-mixed populations (Nowak & May

---

**Publisher's Disclaimer:** This is a PDF file of an unedited manuscript that has been accepted for publication. As a service to our customers we are providing this early version of the manuscript. The manuscript will undergo copyediting, typesetting, and review of the resulting proof before it is published in its final citable form. Please note that during the production process errors may be discovered which could affect the content, and all legal disclaimers that apply to the journal pertain.

1992, 1993, Wilson et al. 1992, Ellison 1993, Herz 1994, Lindgren & Nordahl 1994, Nowak et al. 1994, Killingback & Doebeli 1996, Nakamaru et al. 1997, 1998, Eshel et al. 1998, 1999, Szabó & Tóke 1998, van Baalen & Rand 1998, Szabó et al. 2000, Szabó et al. 2005, Hauert 2001, Irwin & Taylor 2001, Hauert et al. 2002, Szabó & Hauert 2002, Le Galliard et al. 2003, Hauert & Doebeli 2004, Ifti et al. 2004, Santos & Pacheco 2005, Santos et al. 2006, Szabó & Fátth 2007). Spatial models have also been studied in ecology (Levin 1974, Levin & Paine 1974, Durrett & Levin 1994, Hassell et al. 1994, Tainaka 1994, Durrett & Levin 1997, 1998, Tilman & Karieva 1997, Iwasa et al. 1998, Haraguchi & Sasaki 2000, Neuhauser 2001, Pastor-Satorras & Vespignani 2001, Wootton 2001, May 2006) and population genetics (Wright 1943, Kimura 1953, Kimura & Weiss 1964, Maruyama 1970, 1971, Nagylaki 1992, Epperson 2003). Literature of kin selection is useful in analyzing spatial games (Taylor 1992, Taylor & Irwin 2000, Rousset 2004, Lehmann et al. 2007, Taylor et al. 2007)

Evolutionary graph theory (Lieberman et al. 2005, Ohtsuki et al. 2006, Ohtsuki & Nowak 2006a,b, Pacheco et al. 2006a,b, Taylor et al. 2007) is the extension of spatial evolutionary dynamics to general graphs and networks. The members of a population occupy the vertices of a graph. Interactions occur between connected individuals. Many different update rules are possible. Competition for reproduction and playing the game can be described by the same graph or by two different graphs (Ohtsuki et al. 2006, Ohtsuki & Nowak 2006a,b, Ohtsuki et al. 2007a,b). A well-mixed population is defined by a complete graph with identical weights. Spatial games are typically described by regular lattices.

The purpose of this paper is to derive the ESS condition for games on graphs. The paper is structured as follows. In Section 2, we review the definition of evolutionary stability in a well-mixed population. In Section 3, we introduce three different update rules and formulate the replicator equation on graphs (Ohtsuki & Nowak 2006b). Section 4 describes our main results. We give geometrical representations of the ESS conditions on graphs in Section 5 and Section 6. We offer examples and computer simulations in Section 7. Finally, we provide a discussion in Section 8.

## 2 Evolutionary stability in a well-mixed population

Consider a game between two strategies,  $A$  and  $B$ . The payoff matrix is given by

$$\begin{matrix} A & \begin{pmatrix} A & B \\ a & b \\ c & d \end{pmatrix} \\ B & \end{matrix} \quad (1)$$

In a well-mixed population every player meets every other player equally likely. Let  $x_A$  and  $x_B$  be the frequencies of  $A$  and  $B$  players in the population. The average payoffs of  $A$  and  $B$  players are given by

$$\begin{aligned} P_A &= ax_A + bx_B \\ P_B &= cx_A + dx_B. \end{aligned} \quad (2)$$

A population of  $A$  individuals is challenged by a small fraction of  $B$  invaders. The relative abundance of  $B$  players is  $x_B = \varepsilon$ , where  $0 < \varepsilon \ll 1$ . The fraction of  $A$  players is  $x_A = 1 - \varepsilon$ . Strategy  $A$  is evolutionary stable if  $P_A > P_B$  for  $(x_A, x_B) = (1 - \varepsilon, \varepsilon)$ . This condition leads to

$$(a - c)(1 - \varepsilon) + (b - d) \varepsilon > 0. \quad (3)$$

For  $\varepsilon \rightarrow 0$ , the left hand side of (3) is positive if and only if

$$\text{ESS: } 'a > c' \quad \text{or} \quad 'a = c \quad \text{and} \quad b > d'. \quad (4)$$

The condition,  $b > d$ , is only used in the knife-edge case,  $a = c$ .

The evolutionary stability of a strategy in a game with  $n$  strategies can be defined in a similar way. A strategy is ESS if and only if condition (4) holds in pairwise comparison with each of the  $n - 1$  other strategies.

The traditional stability concept in game theory is the Nash equilibrium (Nash 1950, Luce & Raiffa 1957, Fudenberg & Tirole 1991, Binmore 1994, Weibull 1995, Samuelson 1997). For payoff matrix (1), strategy  $A$  is called a ‘Nash equilibrium’ if and only if

$$\text{Nash: } a \geq c. \quad (5)$$

Condition (5) implies that  $A$  is a best reply to itself. In addition, strategy  $A$  is called a ‘strict Nash equilibrium’ if and only if

$$\text{Strict Nash: } a > c. \quad (6)$$

Condition (6) implies that  $A$  is the unique best response to itself. Note that if  $A$  is a strict Nash equilibrium then it is an ESS. If  $A$  is an ESS then it is a Nash equilibrium.

While the condition for a Nash equilibrium depends only on the payoff matrix, a meaningful concept of evolutionary stability is affected by population size (Schaffer 1988, Ficici & Pollack 2000, Nowak et al. 2004, Wild & Taylor 2004, Traulsen et al. 2006) and population structure (Nowak & May 1992, 1993, Nakamaru et al. 1997, Le Galliard et al. 2003).

### 3 Evolutionary game dynamics on graphs

In this section, we introduce three different update rules for evolutionary games on graphs (Ohtsuki et al. 2006, Ohtsuki & Nowak 2006a,b). Then we discuss the ‘replicator equation on graphs’ (Ohtsuki & Nowak 2006b).

We consider an infinitely large population. The structure of the population is described by an infinite, connected, and regular graph of degree  $k$ . A graph is called ‘regular’ when each node has exactly the same number of neighbors; that number is called the ‘degree’ of the graph. Each node represents a player whose strategy is either  $A$  or  $B$ . There are no empty nodes. In this paper, we study  $k > 2$ . For games on cycles,  $k = 2$ , we refer to Ohtsuki & Nowak (2006a).

Each player interacts with all  $k$  neighbors, and obtains an accumulated payoff, denoted by  $P$ . The accumulated payoff is translated into fitness,  $F$ , by the following formula:

$$F = (1 - w) + w \cdot P. \quad (7)$$

Here  $0 \leq w \leq 1$  represents the intensity of selection. If  $w = 0$  then fitness is constant,  $F = 1$ , and independent of the payoff. Throughout the paper, we consider the case of small  $w$ , given by  $0 < w \ll 1$ .

Given the fitnesses of all players, we update the strategy of one player in each elementary time step. Therefore updating is asynchronous. We consider the following three update rules (Ohtsuki et al. 2006, Ohtsuki & Nowak 2006a,b):

- **Birth-Death (BD) updating.** An individual is chosen for reproduction proportional to fitness; the offspring replaces a randomly chosen neighbor.
- **Death-Birth (DB) updating.** A random individual is chosen to die; the  $k$  neighbors compete for the empty site proportional to their fitness.
- **Imitation (IM) updating.** A random player is chosen for updating his strategy; he either adopts a strategy of one of his  $k$  neighbors or remains with his own strategy, proportional to fitness.

Using the pair approximation method (Matsuda et al. 1987, 1992, Nakamaru et al. 1997, 1998, Keeling 1999, van Baalen 2000), Ohtsuki & Nowak (2006b) have shown that for small  $w$  the frequencies of strategies on a regular graph of degree  $k$  can be described by a differential equation. For a  $n \times n$  game with the payoff matrix,  $[a_{ij}]$ , it is given by

$$\dot{x}_i = x_i \left[ \sum_{j=1}^n x_j (a_{ij} + b_{ij}) - \varphi \right]. \quad (8)$$

Here  $x_i$  denotes the frequency of  $i$ -th strategy, a dot represents time derivative, and  $\varphi = \sum_{i,j=1}^n x_i x_j (a_{ij} + b_{ij})$ . For each update rule, the value of  $b_{ij}$  in eq.(8) is calculated from the original payoff matrix,  $[a_{ij}]$ , as

$$\begin{aligned} \text{BD: } b_{ij} &= \frac{a_{ii} + a_{ij} - a_{ji} - a_{jj}}{k-2} \\ \text{DB: } b_{ij} &= \frac{(k+1)a_{ii} + a_{ij} - a_{ji} - (k+1)a_{jj}}{(k+1)(k-2)} \\ \text{IM: } b_{ij} &= \frac{(k+3)a_{ii} + 3a_{ij} - 3a_{ji} - (k+3)a_{jj}}{(k+3)(k-2)}. \end{aligned} \quad (9)$$

Interestingly, differential equation (8) has the form of a replicator equation (Taylor & Jonker 1978, Hofbauer et al. 1979, Zeeman 1980, Weibull 1995, Hofbauer & Sigmund 1998, Nowak 2006) with a transformed payoff matrix,  $[a_{ij} + b_{ij}]$ . Therefore, many aspects of evolutionary dynamics on graphs can be analyzed by studying a standard replicator equation with a transformed payoff matrix, a so-called ‘replicator equation on graphs’. For example, for the  $2 \times 2$  payoff matrix, (1), Ohtsuki & Nowak (2006b) have shown that the transformed payoff matrix is

$$\begin{matrix} A & B \\ B & \end{matrix} \begin{pmatrix} A & B \\ a & b+h \\ c-h & d \end{pmatrix}. \quad (10)$$

The modifier  $h$  depends on the update rule. It is given by

$$\begin{aligned} \text{BB: } h &= \frac{a+b-c-d}{k-2} \\ \text{DB: } h &= \frac{(k+1)a+b-c-(k+1)d}{(k+1)(k-2)} \\ \text{IM: } h &= \frac{(k+3)a+3b-3c-(k+3)d}{(k+3)(k-2)}. \end{aligned} \quad (11)$$

These results hold for infinitely large population size and for  $0 < w \ll 1$ . Regarding a finite population of size  $N$ , Ohtsuki & Nowak (2006b) found that the replicator equation on graphs gives a good approximation if  $Nw \gg 1$ .

In the next section, we use eqs.(10) and (11) to derive the concept of evolutionary stability for graph selection.

#### 4 ESS conditions on graphs

In order to characterize evolutionary stability on graphs, we ask whether rare mutants (of  $\epsilon$  fraction) have an selective advantage over residents. According to the modified payoff matrix (10), if  $a > c - h$  then rare  $B$  mutants are selected against in an  $A$ -population. In this case,  $A$  is ESS when compared to  $B$ . If  $a < c - h$  then  $B$  can invade  $A$  and, therefore,  $A$  is not an ESS. We do not discuss the evolutionary stability of the ‘knife-edge’ case,  $a = c - h$ , because it is ungeneric. Throughout the paper we call

$$\text{ESS on graphs : } a > c - h. \quad (12)$$

the ‘ESS condition on graphs’.

In contrast to the ESS condition on graphs, the conditions for (strict) Nash equilibrium on graphs are not obtained from the modified payoff matrix, (10). By analogy to its counterpart in a well-mixed population, a straightforward definition of (strict) Nash equilibrium on graphs is as follows: a strategy is a (strict) Nash equilibrium on graphs if no one gains a (strictly) higher payoff by switching to the other strategy. Therefore, the conditions for (strict) Nash equilibrium on graphs are the same as those in a well-mixed population, eqs.(5, 6). On graphs, it is possible that a strict Nash equilibrium is not an ESS. It is also possible that an ESS is not a Nash equilibrium. We will discuss this issue further in Section 7.1.

For the three update rules, condition (12) is rewritten as follows:

$$\begin{aligned} \text{ESS on graphs (BD updating):} \\ (k-1)a + b > (k-1)c + d \end{aligned} \quad (13)$$

$$\begin{aligned} \text{ESS on graphs (DB updating):} \\ (k^2-1)a + b > (k^2-k-1)c + (k-1)d \end{aligned} \quad (14)$$

$$\begin{aligned} \text{ESS on graphs (IM updating):} \\ (k^2+2k-3)a + 3b > (k^2+k-3)c + (k+3)d \end{aligned} \quad (15)$$

All these conditions converge to  $a > c$  for  $k \rightarrow \infty$ . This makes sense, because a well-mixed population is described by a fully connected graph.

## 5 The geometry of evolutionary stability

We can provide a beautiful geometrical representation of the ESS conditions (13–15). Figure 1 illustrates the invasion of a homogeneous  $A$  population by an  $\varepsilon$  fraction of  $B$  players. Initially the  $B$  players are sprinkled randomly over the entire population: each vertex changes from  $A$  to  $B$  with probability  $\varepsilon$ , which is very small. The following evolutionary dynamics have two time scales: (i) on a fast time scale the population ‘equilibrates’ locally and  $B$ -clusters are formed, (ii) on a slower time scale the global frequency of  $A$  (and  $B$ ) is changing. This separation of time scales is a consequence of the weak intensity of selection,  $0 < w \ll 1$  (Ohtsuki et al. 2006).

After the local equilibration process, we find that, a  $B$  player, whose one neighbor is already specified, has on average one  $B$  neighbor among his  $k-1$  other neighbors. Thus, in order to intuitively understand the ESS conditions on graphs, (13–15), it is convenient to use a schematic drawing where a half-line of  $B$  players is embedded in a sea of  $A$  players (Fig. 2). If the tip of the half-line is more likely to shrink than to extend, then  $A$  is ESS. Otherwise selection favors the invasion of  $B$ .

For example, let us study the invasion dynamics for **DB** updating. The half-line of  $B$ -players extends in length by one if (i) one of the  $(k-1)$   $A$ -neighbors of the  $B$ -player on the tip is chosen to die and (ii) the  $B$ -player, whose payoff is  $(k-1)c + d$ , wins the competition over the vacancy against  $(k-1)$   $A$ -players, whose payoff is  $ka$ . These events occur with a probability that is proportional to

$$(k+1) \cdot \frac{(1-w) + w\{(k-1)c + d\}}{[(1-w) + w\{(k-1)c + d\}] + (k-1)[(1-w) + w \cdot ka]} \quad (16)$$

A similar calculation shows that the half-line of  $B$ -players shrinks in length by one with a probability proportional to (up to the same constant)

$$1 \cdot \frac{(k-1)[(1-w) + w\{(k-1)a + b\}]}{(k-1)[(1-w) + w\{(k-1)a + b\}] + [(1-w) + w\{(k-2)c + 2d\}]} \quad (17)$$

For small  $w$ , it is easy to see that probability (16) being smaller than probability (17) is equivalent to the ESS condition for **DB** updating, (14). The ESS conditions for **BD** and **IM** updating rules, (13) and (15), can be derived in the same way.

## 6 Intuitive counting over one contested edge

There is a simple, intuitive way to derive the ESS conditions on graph, (13–15). Again we consider the tip of the half-line of  $B$  players. The trick to derive the ESS conditions, (13–15), is to sum up the payoffs of all players involved in the movement of an edge extending from the tip (=a boundary between  $A$  and  $B$  players), but separately for  $A$ -players and for  $B$ -players. Then we compare these total payoffs to see which replacement is more likely to occur at the boundary. If the total payoff of strategy  $A$  exceeds that of  $B$ , then strategy  $A$  is an ESS on graphs.

Figure 3 shows the calculation for birth-death (**BD**) updating. The two players at the boundary are involved in the contest (they are marked with circles). The  $A$ -player has payoff  $(k - 1) + b$ . The  $B$ -player has payoff  $(k - 1)c + d$ . Comparison of these two payoffs immediately leads to the ESS condition for **BD** updating, (13).

Figure 4 describes death-birth (**DB**) updating. We focus on the movement of the boundary which is shown as a dotted line. There are two possibilities.

- i. If the  $A$ -player at the boundary dies (top panel), his  $(k - 1)$   $A$ -neighbors and one  $B$ -neighbor compete for the empty site. Each of the  $(k - 1)$   $A$ -neighbors has payoff  $ka$ , and has one  $B$ -opponent. The  $B$ -player has payoff  $(k - 1)c + d$ . He has  $(k - 1)$   $A$ -opponents. Therefore, his ‘weight’ is  $k - 1$ .
- ii. If the  $B$ -player at the boundary dies (bottom panel), one  $A$ -neighbor and one  $B$ -neighbor (marked with circles) are relevant for the movement of the boundary. Notice that other  $A$ -neighbors are NOT involved in the movement of the boundary, because if one of them replaces the vacancy a different boundary moves. The  $A$ -player has payoff  $(k - 1)a + b$  and has one  $B$ -opponent. The  $B$ -player has payoff  $(k - 2)c + 2d$  and has one  $A$ -opponent.

Comparing the two weighted total payoffs reproduces our ESS condition for **DB** updating, (14). Figure 5 shows how to derive the ESS condition for **IM** updating.

## 7 Numerical examples and computer simulations

### 7.1 Examples

We will now study some examples, which elucidate the difference between ESS in well mixed populations and on sparse graphs.

Let us first consider the following game:

$$\begin{matrix} A & \begin{pmatrix} A & B \\ 1 & 3 \\ 2 & 0 \end{pmatrix} \\ B & \end{matrix} \quad (18)$$

In this example, strategy  $A$  is not an ESS in a well-mixed population. However, it is an ESS on a regular graph of degree  $k = 3$  for all update rules (**BD**, **DB**, and **IM**).

The reason for this discrepancy between well-mixed populations and graph-structured populations can be understood as follows. Imagine that strategy  $A$  dominates the population and that a  $B$ -mutant tries to invade it. The average payoff of the  $B$ -mutant per game is 2. In a well-mixed population, the average payoff of  $A$  players is 1. Hence, strategy  $A$  is not evolutionarily stable. However, in a graph-structured population, the payoff of the  $A$ -neighbors



of the  $B$ -mutant affects selection. These  $A$ -neighbors gain payoff, 3, from the interaction with the  $B$ -mutant, which exceeds the mutant's payoff, 2. Therefore, the  $B$ -mutant fails to invade the population.

The game (18) is an example where strategy  $A$  is not a Nash equilibrium, but is an ESS on graphs.

As a second example, consider the game:

$$\begin{array}{c} A \\ B \end{array} \begin{pmatrix} A & B \\ 2 & 0 \\ 1 & 3 \end{pmatrix}. \quad (19)$$

Strategy  $A$  is an ESS in a well-mixed population. However, it is not an ESS on a regular graph of degree  $k = 3$  for all three update rules (**BD**, **DB**, and **IM**).

Imagine that  $A$  players dominate the population. Their payoff per game is 2. When a  $B$  mutant invades the population, his payoff per game is 1. Therefore, strategy  $A$  resists invasion by strategy  $B$  in a well-mixed population. However, we notice that  $A$  players in the neighborhood of the invading  $B$ -player gain payoff, 0, from the game with  $B$ . Strategy  $B$  considerably reduces the payoff of its  $A$ -neighbors. On graphs it can be adaptive to weaken neighbors with whom one competes (Nakamaru et al. 1997, Nakamaru & Iwasa 2005).

The payoff matrix (19) is an example for a game where strategy  $A$  is a strict Nash equilibrium, but is not an ESS on graphs.

As a third example, consider the Prisoner's Dilemma game (Rapoport & Chammah 1965, Axelrod & Hamilton 1981). Cooperation ( $C$ ) costs  $c$  for the donor and yields benefit,  $b$ , for the recipient. Defection ( $D$ ) yields zero payoff to both players. The payoff matrix is

$$\begin{array}{c} C \\ D \end{array} \begin{pmatrix} C & D \\ b-c & -c \\ b & 0 \end{pmatrix}. \quad (20)$$

In a well-mixed population, defection ( $D$ ) is the unique ESS of the game. It is also true for games on graphs under **BD** updating. However, as is shown in Ohtsuki & Nowak (2006b), cooperation is the only ESS on a graph of degree  $k$  under **DB** updating whenever  $b/c > k$  is satisfied. For **IM** updating,  $b/c > k + 2$  is the decisive condition for cooperation to be the unique ESS on graphs.

For the more general Prisoner's Dilemma payoff matrix,

$$\begin{array}{c} C \\ D \end{array} \begin{pmatrix} C & D \\ R & S \\ T & P \end{pmatrix}, \quad (21)$$

where  $T > R > P > S$ , it is possible that both cooperation and defection are ESSs on graphs. It is also possible that neither of them is an ESS on graphs (see Ohtsuki & Nowak (2006b)) depending on the parameter values and the degree of the graph,  $k$ .

## 7.2 Computer simulations

In order to test the validity of our analytic results, eqs.(13–15), we have run extensive computer simulations for each of the three update rules. We have studied random regular graphs of degrees  $k = 3, 4, 5, 6$  and lattices of degrees  $k = 3, 4, 6$ .

We study a population of size  $N = 10^4$ . At the beginning of each run, 100 random vertices are changed for  $A$  to  $B$ . We run simulations for 5 generations, or equivalently,  $5N$  asynchronous updating steps. This means that each player in the population experiences, on average, 5 potential updating events. After 5 generations, we count the number of  $B$  players in the population. We conducted simulations  $10^4$  times for each set of parameters. Each data point in our result represents the average number of  $B$  players after 5 generations over  $10^4$  runs. In studying random regular graphs, we generate a new graph every  $10^2$  runs, in order to avoid the effect of a particular configuration of a graph. Throughout our simulations, we use  $w = 0.01$ . Therefore we have  $Nw = 100$ , which meets the requirement of  $Nw \gg 1$ .

Figure 6 shows the result of computer simulations for random regular graphs. Note that the analytic predictions, eqs.(13–15), agree well with the simulations. Each column of panels in Figure 6 corresponds to one of the three update rules, **BD** (left), **DB** (center), and **IM** (right). In the upper three panels, we study the payoff matrix,  $(a, b, c, d) = (0, b, 1, 0)$ . Equations (13–15) predict that strategy  $A$  is an ESS if

$$\begin{aligned} \text{BD: } & b > k - 1 \\ \text{DB: } & b > k^2 - k - 1 \\ \text{IM: } & b > \frac{k^2 + k - 3}{3}. \end{aligned} \quad (22)$$

In the lower three panels, we study  $(a, b, c, d) = (1, 0, 0, d)$ . In this case our predictions, eqs. (13–15), tell us that strategy  $A$  is an ESS if

$$d < k - 1 \quad (23)$$

for all three update rules.

In Figure 7, we show the results of computer simulations for lattices of degrees  $k = 3$  (triangular),  $k = 4$  (square), and  $k = 6$  (hexagonal). We find very good agreement between the simulations and the theoretical predictions for the triangular lattice, fairly good for the square lattice, but no good agreement for the hexagonal lattice.

The reason for this deviation can be understood as follows. The calculations of Ohtsuki & Nowak (2006b) are based on pair approximation, which is mathematically correct for Bethe lattices (= Cayley trees), that have no loops. However, both random regular graphs and lattices contain many loops. The existence of loops causes a discrepancy between simulation results and analytic conditions. The precision of the pair approximation depends on the length,  $L$ , of the existing loops. The smaller  $L$  is, the worse pair approximation tends to be.

For Bethe lattices we have  $L = \infty$ . Thus pair approximation is correct. For large random regular graphs,  $L$  is usually very large. For triangular, square, and hexagonal lattices, however, there are many loops with length  $L = 6, 4$  and  $3$ , respectively (see Figure 8). Therefore, for those lattices we expect that predictions based on pair approximation do not work well.

## 8 Conclusion

We have derived ESS conditions for games on regular graphs of degree  $k$ . A resident strategy,  $A$ , can resist invasion by a small fraction of  $B$  players if

$$\begin{aligned} \text{BD updating: } & (k - 1)a + b > (k - 1)c + d \\ \text{DB updating: } & (k^2 - 1)a + b > (k^2 - k - 1)c + (k - 1)d \\ \text{IM updating: } & (k^2 + 2k - 3)a + 3b > (k^2 + k - 3)c + (k + 3)d \end{aligned} \quad (24)$$

The parameters,  $a, b, c, d$ , denote the entries of the payoff matrix, (1), which defines the game between strategies  $A$  and  $B$ . The ESS conditions (24) hold for a weak intensity of selection,  $0 < w \ll 1$ , and for infinitely large population size.



For well-mixed populations, which are given by the complete graph,  $k \rightarrow \infty$ , all three conditions converge to  $a > c$ . Thus, for infinite  $k$ , the decisive criterion is what does the resident get from itself,  $a$ , compared to what does the invader get from the resident,  $c$ . But for finite  $k$ , the payoff values  $b$  and  $d$  also matter; it is crucial to know, what the resident gets from the invader,  $b$ , and what the invader gets from itself,  $d$ .

For **BD** updating,  $a$  is as important as  $c$  (both parameters have the same weight,  $k - 1$ , in the ESS condition), and  $b$  is as important as  $d$ . For **DB** and **IM** updating, however,  $a$  is more important than  $c$ , and  $b$  is less important than  $d$ . For all three update rules, we find that  $a$  and  $c$  enter into the ESS conditions with greater weights than  $b$  and  $d$ .

The traditional ESS criterion of well-mixed populations is neither necessary nor sufficient to guarantee evolutionary stability in structured populations.

### Acknowledgments

Support from the John Templeton Foundation and the NSF/NIH joint program in mathematical biology (NIH grant R01GM078986) is gratefully acknowledged. The Program for Evolutionary Dynamics at Harvard University is sponsored by Jeffrey Epstein.

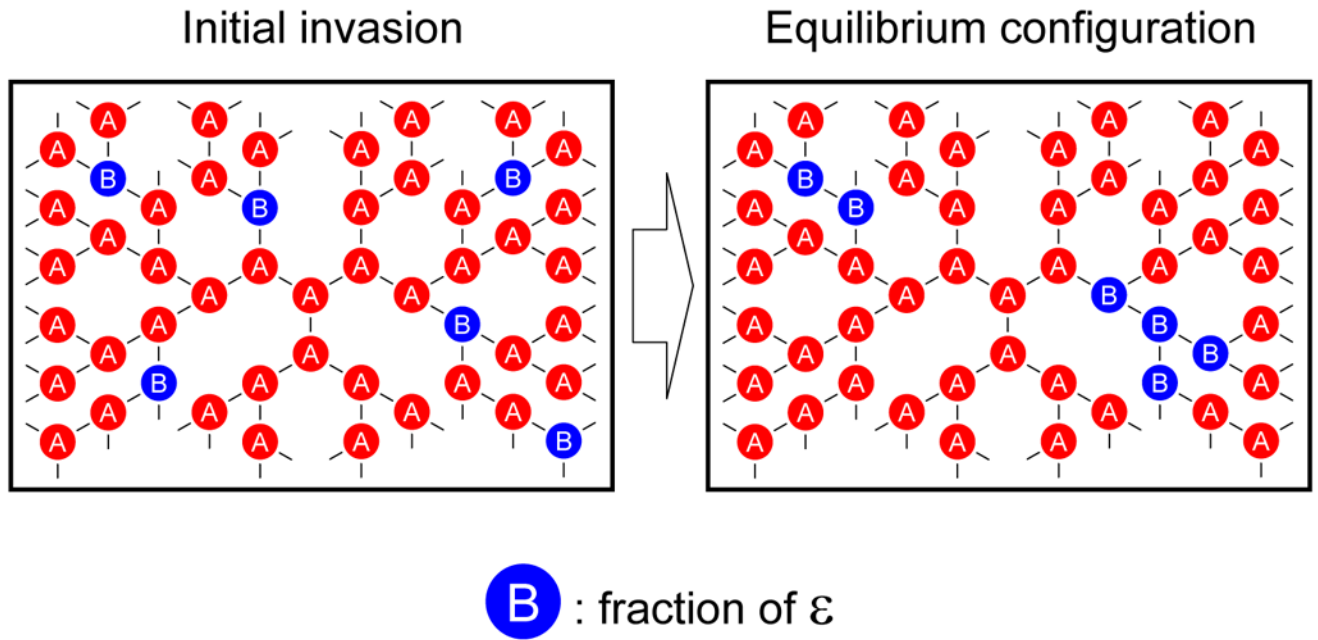
### References

- Axelrod R, Hamilton WD. The evolution of cooperation. *Science* 1981;211:1390–1396. [PubMed: 7466396]
- Binmore, K. *Playing fair*. Vol. 1. Cambridge: MIT Press; 1994. Game theory and the social contract.
- Durrett R, Levin SA. The importance of being discrete (and spatial). *Theor. Popul. Biol* 1994;46:363–394.
- Durrett R, Levin SA. Allelopathy in spatially distributed populations. *J. Theor. Biol* 1997;185:165–171. [PubMed: 9344720]
- Durrett R, Levin SA. Spatial aspects of interspecific competition. *Theor. Popul. Biol* 1998;53:30–43.
- Ellison G. Learning, local interaction, and coordination. *Econometrica* 1993;61:1047–1071.
- Epperson, BK. *Geographical genetics*. Princeton: Princeton University Press; 2003.
- Eshel I, Samuelson L, Shaked A. Altruists, egoists, and hooligans in a local interaction model. *Am. Econ. Rev* 1998;88:157–179.
- Eshel I, Sansone E, Shaked A. The emergence of kinship behavior in structured populations of unrelated individuals. *Int. J. Game Theory* 1999;28:447–463.
- Ficici, S.; Pollack, J. Effects of finite populations on evolutionary stable strategies. In: Whitley, D., editor. *Proceedings of the 2000 genetic and evolutionary computation conference*; San Francisco: Morgan-Kaufmann; 2000. p. 927-934.
- Fudenberg, D.; Tirole, J. *Game theory*. Cambridge: MIT Press; 1991.
- Haraguchi Y, Sasaki A. The evolution of parasite virulence and transmission rate in a spatially structured population. *J. Theor. Biol* 2000;203:85–96. [PubMed: 10704294]
- Hassell MP, Comins HN, May RM. Species coexistence and self-organizing spatial dynamics. *Nature* 1994;370:290–292.
- Hauert C. Fundamental clusters in spatial  $2 \times 2$  games. *Proc. R. Soc. Lond. B* 2001;268:761–769.
- Hauert C, De Monte S, Hofbauer J, Sigmund K. Volunteering as red queen mechanism for cooperation in public goods game. *Science* 2002;296:1129–1132. [PubMed: 12004134]
- Hauert C, Doebeli M. Spatial structure often inhibits the evolution of cooperation in the snowdrift game. *Nature* 2004;428:643–646. [PubMed: 15074318]
- Herz AV. Collective phenomena in spatially extended evolutionary games. *J. Theor. Biol* 1994;169:65–87. [PubMed: 7934074]
- Hofbauer J, Schuster P, Sigmund K. A note on evolutionarily stable strategies and game dynamics. *J. Theor. Biol* 1979;81:609–612. [PubMed: 537389]

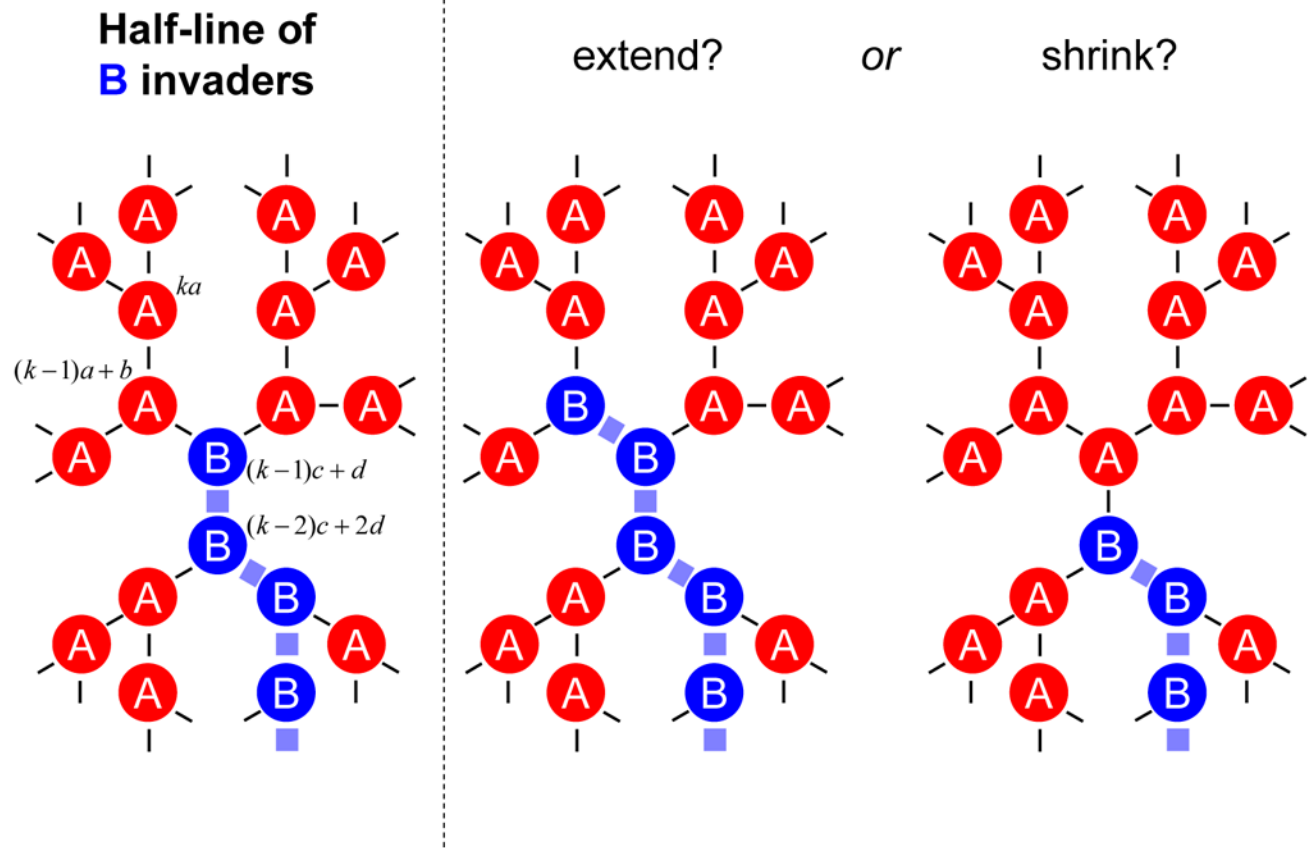
- Hofbauer, J.; Sigmund, K. *Evolutionary Games and Population Dynamics*. Cambridge, UK: Cambridge Univ. Press; 1998.
- Ifti M, Killingback T, Doebeli M. Effects of neighbourhoodsize and connectivity on the spatial Continuous Prisoner's Dilemma. *J. Theor. Biol* 2004;231:97–106. [PubMed: 15363932]
- Irwin A, Taylor PD. Evolution of altruism in a stepping-stone population with overlapping generations. *Theor. Popul. Biol* 2001;60:315–325. [PubMed: 11878832]
- Iwasa Y, Nakamaru M, Levin SA. Allelopathy of bacteria in a lattice population: competition between colicin-sensitive and colicin-producing strains. *Evol. Ecol* 1998;12:785–802.
- Keeling MJ. The effects of local spatial structure on epidemiological invasions. *Proc. R. Soc. Lond. B* 1999;266:859–869.
- Killingback T, Doebeli M. Spatial evolutionary game theory: Hawks and Doves revisited. *Proc. R. Soc. Lond. B* 1996;263:1135–1144.
- Kimura M. Stepping stone model of population. *Ann. Rep. Nat. Inst. Genetics (Japan)* 1953;3:63–65.
- Kimura M, Weiss GH. The stepping stone model of population structure and the decrease of genetical correlation with distance. *Genetics* 1964;49:561–576. [PubMed: 17248204]
- Le Galliard J, Ferrière R, Dieckman U. The adaptive dynamics of altruism in spatially heterogeneous populations. *Evolution* 2003;57:1–17. [PubMed: 12643563]
- Lehmann L, Keller L, Sumpter DJT. The evolution of helping and harming on graphs: the return of the inclusive fitness effect. *J. Evol. Biol* 20:2284–2295. [PubMed: 17956391]
- Levin SA. Dispersion and population interactions. *Am. Nat* 1974;108:207–228.
- Levin SA, Paine RT. Disturbance, patch formation, and community structure. *Proc. Natl. Acad. Sci. USA* 1974;71:2744–2747. [PubMed: 4527752]
- Lieberman E, Hauert C, Nowak MA. Evolutionary Dynamics on Graphs. *Nature* 2005;433:312–316. [PubMed: 15662424]
- Lindgren K, Nordahl MG. Evolutionary dynamics of spatial games. *Physica D* 1994;75:292–309.
- Luce, RD.; Raiffa, H. *Games and Decision*. New York: John Wiley and Sons; 1957.
- Maruyama T. On the fixation probability of mutant genes in a subdivided population. *Gen. Res* 1970;15:221–226.
- Maruyama T. An invariance property of a structured population. *Gen. Res* 1971;18:81–84.
- Matsuda, H.; Tamachi, N.; Sasaki, A.; Ogita, N. A lattice model for population biology. In: Teramot, E.; Yamaguti, M., editors. *Mathematical topics in biology, morphogenesis and neurosciences*. 1987. p. 154–161. Springer Lecture Notes in Biomathematics 71
- Matsuda H, Ogita N, Sasaki A, Sato K. Statistical mechanics of population - the lattice Lotka-Volterra model. *Prog. Theor. Phys* 1992;88:1035–1049.
- May RM. Network structure and the biology of populations. *Trends. Ecol. Evol* 2006;21:394–399. [PubMed: 16815438]
- Maynard Smith J, Price G. The logic of animal conflicts. *Nature* 1973;246:15–18.
- Maynard Smith J. The theory of games and the evolution of animal conflicts. *J. Theor. Biol* 1974;47:209–221. [PubMed: 4459582]
- Maynard Smith, J. *Evolution and the theory of games*. Cambridge University Press; 1982.
- Maynard Smith J. Can a mixed strategy be stable in a finite population? *J. Theor. Biol* 1988;130:247–251.
- Nagylaki, T. *Theoretical population genetics*. Berlin: Springer-Verlag; 1992.
- Nakamaru M, Matsuda H, Iwasa Y. The evolution of cooperation in a lattice structured population. *J. Theor. Biol* 1997;184:65–81. [PubMed: 9039401]
- Nakamaru M, Nogami H, Iwasa Y. Score-dependent fertility model for the evolution of cooperation in a lattice. *J. Theor. Biol* 1998;194:101–124. [PubMed: 9778428]
- Nakamaru M, Iwasa Y. The evolution of altruism by costly punishment in the lattice structured population: score-dependent viability versus score dependent fertility. *Evol. Ecol. Res* 2005;7:853–870.
- Nash JF. Equilibrium points in  $n$ -person games. *Proc. Natl. Acad. Sci. USA* 1950;36:48–49. [PubMed: 16588946]

- Neill DB. Evolutionary stability for large populations. *J. Theor. Biol* 2004;227:397–401. [PubMed: 15019506]
- Neuhauser C. Mathematical challenges in spatial ecology. *Not. AMS* 2001;48:1304–1314.
- Nowak MA, May RM. Evolutionary games and spatial chaos. *Nature* 1992;359:826–829.
- Nowak MA, May RM. The spatial dilemmas of evolution. *Int. J. Bifurcat. Chaos* 1993;3:35–78.
- Nowak MA, Bonhoeffer S, May RM. More spatial games. *Int. J. Bifurcat. Chaos* 1994;4:33–56.
- Nowak MA, Sasaki A, Taylor C, Fudenberg D. Emergence of cooperation and evolutionary stability in finite populations. *Nature* 2004;428:646–650. [PubMed: 15071593]
- Nowak MA, Sigmund K. Evolutionary Dynamics of Biological Games. *Science* 2004;303:793–799. [PubMed: 14764867]
- Nowak, MA. Evolutionary Dynamics. MA: Harvard University Press; 2006.
- Ohtsuki H, Hauert C, Lieberman E, Nowak MA. A simple rule for the evolution of cooperation on graphs and social networks. *Nature* 2006;441:502–505. [PubMed: 16724065]
- Ohtsuki H, Nowak MA. Evolutionary games on cycles. *Proc. R. Soc. B* 2006a;273:2249–2256.
- Ohtsuki H, Nowak MA. The replicator equation on graphs. *J. Theor. Biol* 2006b;243:86–97. [PubMed: 16860343]
- Ohtsuki H, Nowak MA, Pacheco J. Breaking the symmetry between interaction and replacement in evolutionary dynamics on graphs. *Phys. Rev. Lett* 2007a;98:108106. [PubMed: 17358573]
- Ohtsuki H, Pacheco J, Nowak MA. Evolutionary graph theory: Breaking the symmetry between interaction and replacement. *J. Theor. Biol* 2007b;246:681–694. [PubMed: 17350049]
- Pacheco JM, Traulsen A, Nowak MA. Active linking in evolutionary games. *J. Theor. Biol* 2006a; 243:437–443. [PubMed: 16901509]
- Pacheco JM, Traulsen A, Nowak MA. Coevolution of strategy and structure in complex networks with dynamical linking. *Phys. Rev. Lett* 2006b;97:258103. [PubMed: 17280398]
- Pastor-Satorras R, Vespignani A. Epidemic spreading in scale-free networks. *Phys. Rev. Lett* 2001;86:3200–3203. [PubMed: 11290142]
- Rapoport, A.; Chammah, AM. Prisoners Dilemma: A study in conflict and cooperation. Ann Arbor, USA: The University of Michigan Press; 1965.
- Rousset, F. Genetic structure and selection in subdivided populations. Princeton: Princeton Univ. Press; 2004.
- Samuelson, L. Evolutionary games and equilibrium selection. Cambridge: MIT Press; 1997.
- Santos FC, Pacheco JM. Scale-free networks provide a unifying framework for the emergence of cooperation. *Phys. Rev. Lett* 2005;95:098104. [PubMed: 16197256]
- Santos FC, Pacheco JM, Lenaerts T. Evolutionary dynamics of social dilemmas in structured heterogeneous populations. *Proc. Natl. Acad. Sci. USA* 2006;103:3490–3494. [PubMed: 16484371]
- Schaffer M. Evolutionarily stable strategies for a finite population and a variable contest size. *J. Theor. Biol* 1988;132:469–478. [PubMed: 3226137]
- Szabó G, Tóke C. Evolutionary prisoner's dilemma game on a square lattice. *Phys. Rev. E* 1998;58:69–73.
- Szabó G, Antal T, Szabó P, Droz M. Spatial evolutionary prisoner's dilemma game with three strategies and external constraints. *Phys. Rev. E* 2000;62:1095–1103.
- Szabó G, Hauert C. Phase transitions and volunteering in spatial public goods games. *Phys. Rev. Lett* 2002;89:118101. [PubMed: 12225171]
- Szabó G, Vukov J, Szolnoki A. Phase diagrams for an evolutionary prisoner's dilemma game on two-dimensional lattices. *Phys. Rev. E* 2005;72:047107.
- Szabó G, Fáth G. Evolutionary games on graphs. *Phys. Rep* 2007;446:97–216.
- Tainaka K. Vortices and strings in a model ecosystem. *Phys. Rev. E* 1994;50:3401–3409.
- Taylor PD. Altruism in viscous populations - an inclusive fitness approach. *Evol. Ecol* 1992;6:352–356.
- Taylor PD, Irwin AJ. Overlapping generations can promote altruistic behavior. *Evolution* 2000;54:1135–1141. [PubMed: 11005283]
- Taylor PD, Jonker L. Evolutionary stable strategies and game dynamics. *Math. Biosci* 1978;40:145–156.

- Taylor PD, Day T, Wild G. Evolution of cooperation in a finite homogeneous graph. *Nature* 2007;447:469–472. [PubMed: 17522682]
- Tilman, D.; Kareiva, P., editors. *Monographs in population biology*. Princeton: Princeton University Press; 1997. *Spatial ecology: the role of space in population dynamics and interspecific interactions*.
- Traulsen A, Pacheco JM, Imhof LA. Stochasticity and evolutionary stability. *Phys. Rev. E* 2006;74:021905.
- van Baalen M, Rand DA. The unit of selection in viscous populations and the evolution of altruism. *J. Theor. Biol* 1998;193:631–648. [PubMed: 9750181]
- van Baalen, M. Pair approximations for different spatial geometries. In: Dieckmann, U.; Law, R.; Metz, JAJ., editors. *The geometry of ecological interactions: simplifying spatial complexity*. Cambridge, UK: Cambridge University Press; 2000. p. 359-387.
- Weibull, .; Jörgen, . *Evolutionary Game Theory*. Cambridge: MIT Press; 1995.
- Wild G, Taylor PD. Fitness and evolutionary stability in game theoretic models of finite populations. *Proc. R. Soc. Lond. B* 2004;271:2345–2349.
- Wilson DS, Pollock GB, Dugatkin LA. Can altruism evolve in purely viscous populations? *Evol. Ecol* 1992;6:331–341.
- Wootton JT. Local interactions predict large-scale pattern in empirically derived cellular automata. *Nature* 2001;413:841–844. [PubMed: 11677606]
- Wright S. Isolation by distance. *Genetics* 1943;28:114–138. [PubMed: 17247074]
- Zeeman, EC. Population dynamics from game theory. In: Nitecki, A.; Robinson, C., editors. *Proceedings of an international conference on global theory of dynamical systems*. Berlin: Springer; 1980. *Lecture Notes in Mathematics* 819



**Figure 1.**  
Local configuration of rare  $B$  mutants quickly equilibrates into clusters, without changing the total number of initial  $B$  players.

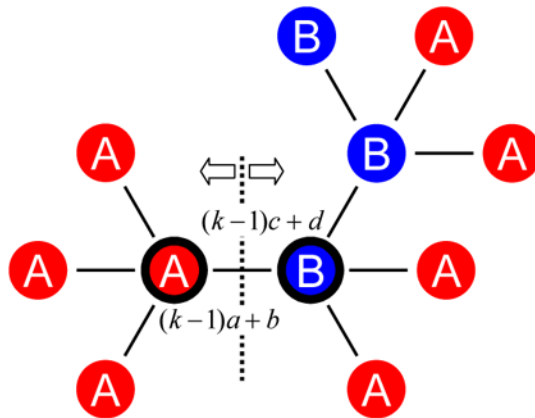


**Figure 2.** A schematic drawing where rare *B*-mutants invade the population of *A*-players in a half-line shape. The number shown next to player is his payoff. When the half-life is more likely to shrink than to extend, strategy *A* is an ESS.



## Birth-death (BD) updating

**A** is an ESS on graphs if  
 $(k-1)a + b > (k-1)c + d$

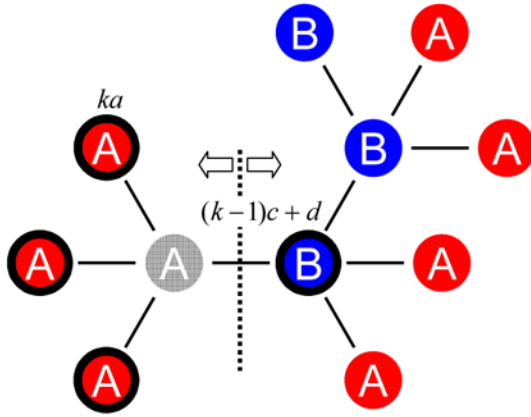


**A** payoff:  $\{(k-1)a + b\} \times 1$

**B** payoff:  $\{(k-1)c + d\} \times 1$

**Figure 3.**

A simple way to reproduce the ESS condition for **BD** updating. The focal boundary is drawn in a dotted line. Those who are involved in the movement of the boundary are marked in circles. Payoffs are shown next to players.



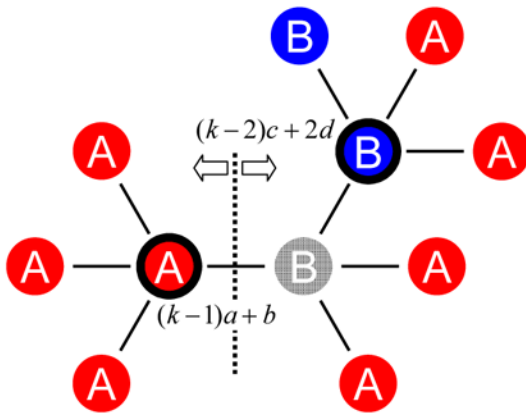
A payoff:  $(k - 1) \times ka \times 1$

B payoff:  $\{(k - 1)c + d\} \times (k - 1)$



**Death-birth (DB) updating**

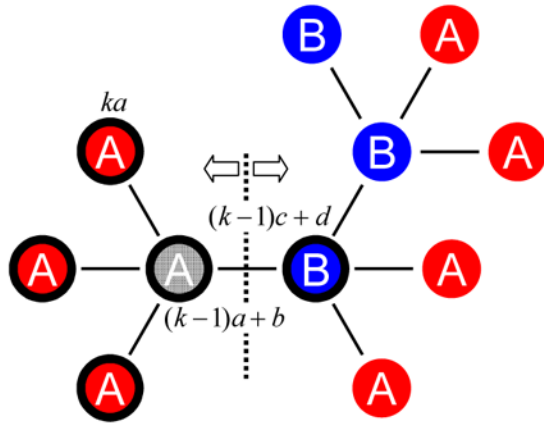
A is an ESS on graphs if  $(k^2 - 1)a + b > (k^2 - k - 1)c + (k + 1)d$



A payoff:  $\{(k - 1)a + b\} \times 1$

B payoff:  $\{(k - 2)c + 2d\} \times 1$

**Figure 4.** A simple way to reproduce the ESS condition for **DB** updating. The focal boundary is drawn in a dotted line. Those who are involved in the movement of the boundary are marked with circles. Payoffs are shown next to players. Top: when the A-player at the boundary dies. Bottom: when the B-player at the boundary dies.

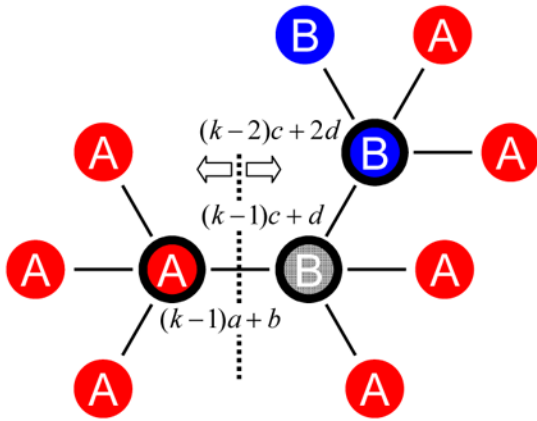


A payoff:  $\begin{cases} (k-1) \times ka \times 1 \\ \{(k-1)a+b\} \times 1 \end{cases}$

B payoff:  $\{(k-1)c+d\} \times k$

**Imitation (IM) updating**

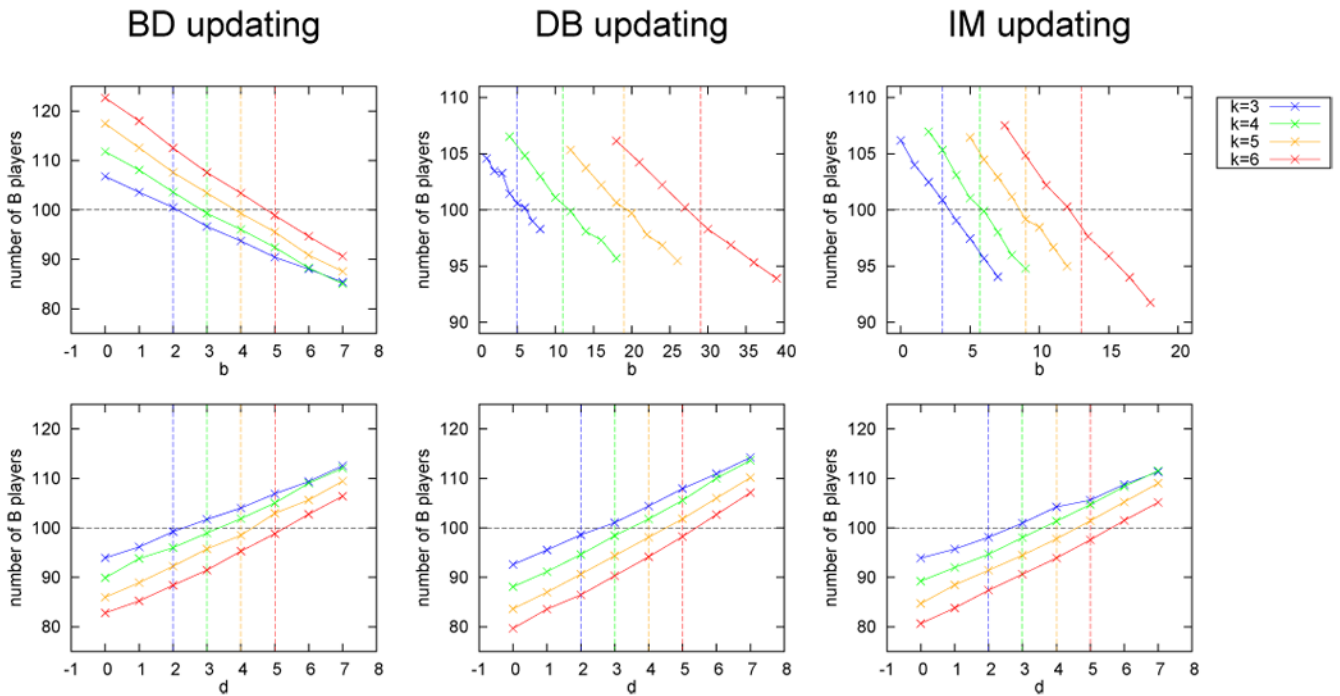
A is an ESS on graphs if  $(k^2 + 2k - 3)a + 3b > (k^2 + k - 3)c + (k + 3)d$



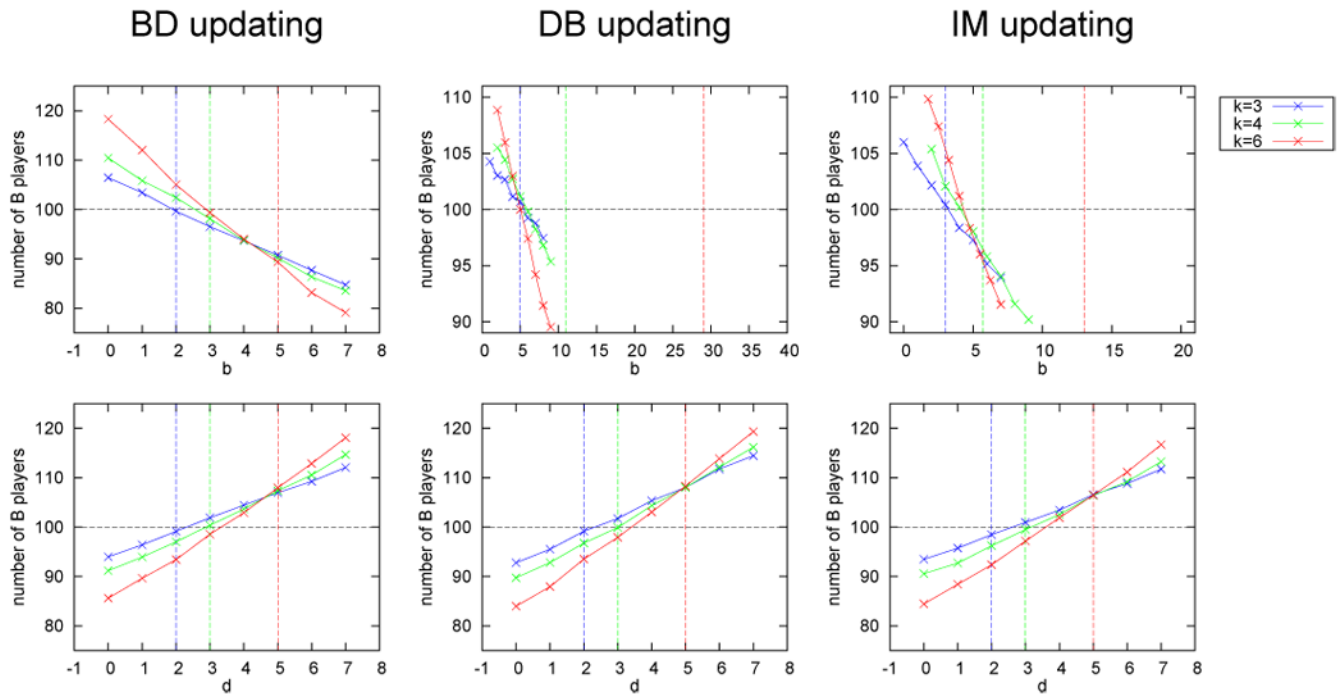
A payoff:  $\{(k-1)a+b\} \times 2$

B payoff:  $\begin{cases} \{(k-1)c+d\} \times 1 \\ \{(k-2)c+2d\} \times 1 \end{cases}$

**Figure 5.** A simple way to reproduce the ESS condition for **IM** updating. The focal boundary is drawn in a dotted line. Those who are involved in the movement of the boundary are marked with circles. Top: when the A-player at the boundary dies. Bottom: when the B-player at the boundary dies.

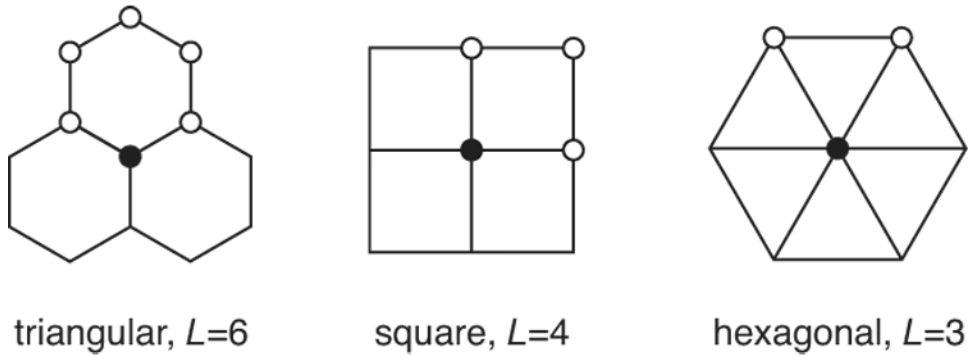


**Figure 6.** Computer simulation results for random regular graphs of degrees  $k = 3$  (blue),  $k = 4$  (green),  $k = 5$  (orange), and  $k = 6$  (red). Each column of panels in the figure represents one of the three update rules, **BD** (panels in the left), **DB** (panels in the center), and **IM** (panels in the right). In the top three panels, we study the parameter  $(a, b, c, d) = (0, b, 1, 0)$  so  $b$  is the only free parameter, which is shown in each x-axis. In the bottom three, we study the parameters  $(a, b, c, d) = (1, 0, 0, d)$ , so  $d$  is the free parameter shown in each x-axis. The y-axis of each panel represents the average number of  $B$  players after 5 generations over  $10^4$  runs. In each small panel, the initial number of  $B$  players, that is  $n_B = 100$ , is shown by the black horizontal dotted line. Thus, the number of  $B$  players after 5 generation being below this threshold,  $n_B = 100$ , implies that strategy  $A$  is an ESS. For each degree  $k$ , simulation results are plotted in a corresponding color with 'x'-symbols. A colored vertical dotted line represents the theoretical prediction, eqs.(22–23). The simulation data show a perfect agreement with theoretical predictions if both data plots and a vertical dotted line in the same color intersect with the black horizontal dotted line exactly at the same point.



**Figure 7.**

The average number of  $B$  players after 5 generations, for lattices of degrees  $k = 3$  (triangular, in blue),  $k = 4$  (square, in green), and  $k = 6$  (hexagonal, in red). All the other conditions, such as update rules and parameters used, are the same and in the same order as in Figure 6. We find that results for hexagonal lattices (in red) show a particularly poor agreement with theoretical predictions.



**Figure 8.** The length of the minimal loop,  $L$ , is shown for triangular, square, and hexagonal lattices, respectively.